

Hinowa[®]
the future is now



HS701E Electric Minidumper

LITHIUM-ION



The minidumper equipped with lithium batteries, Powerful, Fast and Efficient



Advantages:

- Complete **absence of exhaust gases**
- Possibility of **operating with low noise levels** (e.g. in historic centers, near homes or inside buildings)
- **High battery pack autonomy** equal to one working day
- Extremely compact dimensions
- Absence of "memory effect" which makes it possible to charge the battery pack at any residual capacity without affecting the battery life of the lithium battery pack.
- Power and speed comparable to diesel model



Features

ELECTRIC POWERED

Number of drive motors.....	2
Type.....	AC 48Vdc (IP67)
Battery.....	48V, 120Ah
Battery charger.....	3 KW 80-240V
Recharging time.....	3 hours (100%)

PERFORMANCE

Capacity.....	700 kg
Dumper bed capacity.....	0,34 m ³
Translation speed.....	4 km/h
Max. inclination.....	15°

OPERATING WEIGHT

Construction version.....	590 kg
Self loading version.....	740 kg

Elevated protection level of the traction motors used (P67 – 6=powder, 7=water). This high protection level is obtained by using innovating electric Internal Permanent Magnet traction motors instead of the traditional hydraulic ones, and it even allows to cross water bodies with the tracks.



Available versions:

- with standard dumper bed and fixed undercarriage (758mm)
- with self-loading dumper bed and undercarriage with widening system (758-1058mm)



New control panel for an easy and safe use, with ergonomic joysticks and enabling button to prevent the operator from making accidental movements and with two available speeds: "ecomode" for uneven surfaces and energy saving, "power" for flat surfaces.

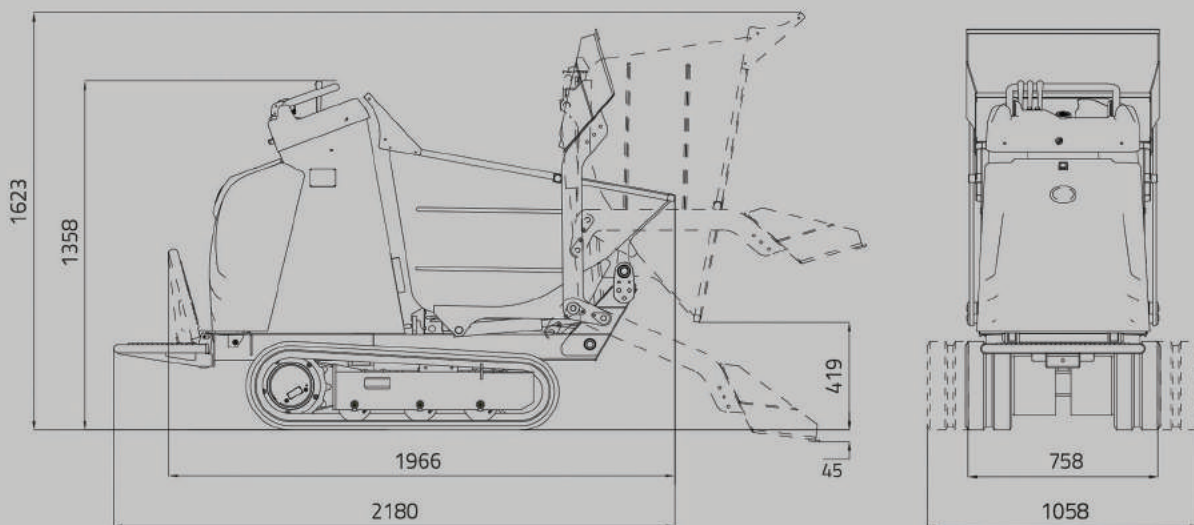



HINOWA S.p.A.
www.hinowa.com • info@hinowa.com
Via Fontana • 37054 Nogara • Verona • ITALY
Tel. +39 0442.539100 • Fax +39 0442.539075